

MOTOR OPERATOR

DIRECT DRIVE & APEX™ SMARTCONTROLLER

Extreme® 300 Series Performance Door and Grille

The motor and advanced control system shipped with each door is specifically designed for reliability and longevity when used as a rolling steel door operator. The hollow shaft motor unit features a direct drive gear reducer, emergency hand chain and a high efficiency motor and solenoid brake.

The advanced control system is a solid state, microprocessor-based control system. It represents the latest in rolling steel door drive technology and has been configured and set-up exclusively for each door.

SPECIFICATIONS

Drive System	Hollow shaft worm gear with integral anti-fallback device, emergency manual operation, integrated absolute encoder, and electric motor
Operation	Soft Stop and Soft Start
Control	Advanced logic PCB control, with variable frequency drive
Voltage	120/1/60 V ac* 230/1/60 V ac** 208/230/3/60 V ac 460/3/60 V ac 575/3/60 V ac
NEMA Rating	NEMA 4/4X, 12" x 24" x 8" enclosure standard - Flexible conduit provided with "plug & play" electrical connectors for Motor and Control Panel interconnection
Cycle Rating	300,000 or 2 Years
Obstruction Detection	PNP type, NC photo eye and Relay type light curtain are standard; motion detectors and additional photo eyes are available as options.
24 V dc Outputs	A 24 V dc, 1A output is allotted for connection to the standard accessories. This output is available through several output terminals on the board, but the total current draw of all the devices connected should not exceed 1A.
Auxiliary Outputs	The Auxiliary output contacts are not intended to be used to route power supply voltages to other components. They are rated as switching contacts for control voltages only. Total current should not exceed 200mA.

* Single phase available up to 2HP only.

** 120 V ac available for 1HP only.

MOTOR OPERATOR **DIRECT DRIVE & APEX™ SMARTCONTROLLER**

Extreme® 300 Series Performance Door and Grille

DRIVE UNIT

HP	Weight (lbs)	MOTOR DIMENSIONS (In)		
		DIM A	DIM B	DIM C
1	79	23.091	12.933	6.498
2	115	25.138	13.445	6.988
3-1/3	130	29.661	15.217	6.413

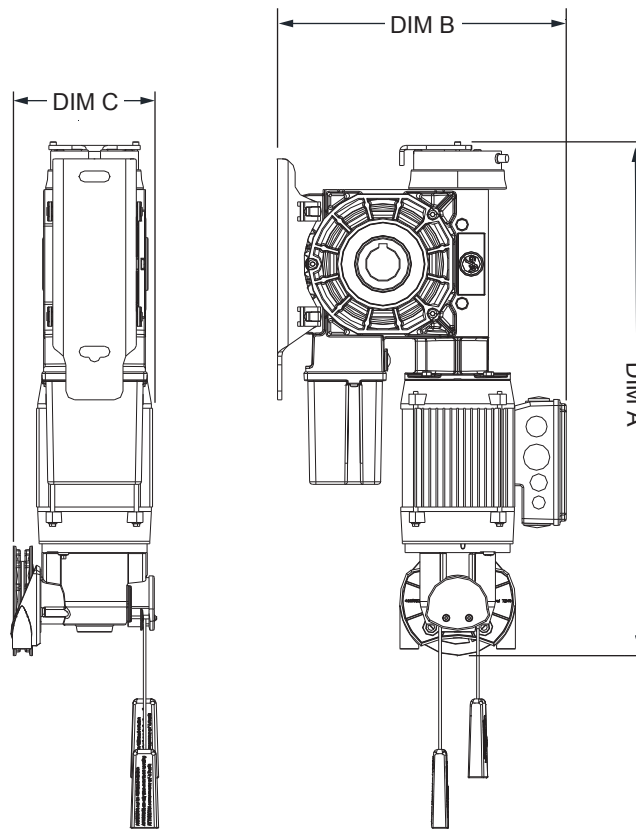

Volt	Phase	1HP	2HP	3.33HP
120*	1	16.5	NA	NA
230	1	6.3	7.7	NA
230	3	6.3	7.7	13.3
460	3	3.5	4.5	8.3
575	3	3.5	4.5	8.3

*120 V ac step up transformer is used in conjunction with a 230 V ac, 1 PH Controller